

POWERS® Controls

GA 142 AP Analog Pressure Gauges

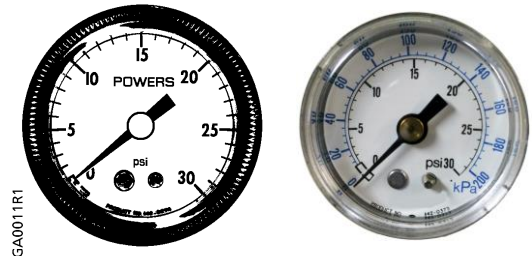

Description The GA 142 Analog Pressure Gauge is a round dial instrument displaying the value of input pressure over an angular displacement of 270°.

Specifications	Accuracy	2-1/2% of full scale for middle half of the scale, 3-1/2% elsewhere
	Connection	1/8-inch NPT male or barbed connector for 1/4-inch OD tubing. See Table 2
Shipping weight	1-1/2 inches	0.5 lb (0.23 kg)
	2-1/2 inches	1 lb (0.45 kg)

Operation As the input pressure increases, the curved bourdon tube tends to straighten out. This action moves the gear and linkage, which is attached to the end of the bourdon tube, making the pointer rotate clockwise.

Calibration and Adjustments Use a master gauge to check the pressure reading. If the gauge does not indicate this measurement, adjust the gauge pointer.

Table 1. Product Numbers.

Range	Product Number			
	1-1/2-in		2-1/2-in	
	Panel-mount	Pipe-mount	Panel-mount	Pipe-mount
0 to 30 psi	142-0274 (barb)	—	142-0277 (barb)	142-0311 (back)
0 to 30 psi 0 to 200 kPa	—	142-0373* (back) 142-0426* (bottom)	—	—
0 to 30 psi 0 to 200 Kpa RoHS Certified	—	142-0473* (back) 142-0476* (bottom)	—	—
0 to 100 psi	—	—	—	142-0312 (back)
0 to 160 psi	—	—	—	142-0313 (back)

* Dual Scale Gauges. Pipe-mount fitting threads are Teflon taped. No logo.

Table 2. Hole Sizes for Panel-mounted Gauges.

Gauge Size Inches (mm)	Hole Size Inches (mm)	Cutout used in Standard Panel Template*
1-1/2 (38)	1-11/16 (42)	G-1
2-1/2 (64)	2-21/32 (68)	G-3

* See 155-223P25 (TB 196) for further information.

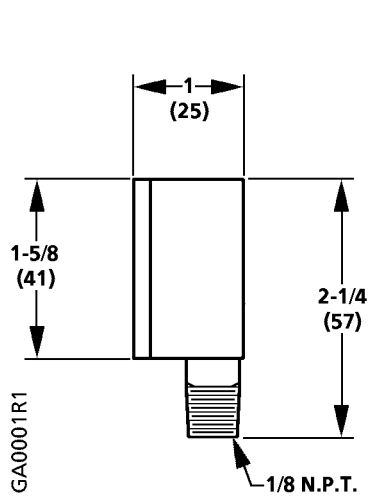

Figure 1. Dimensions for 142-0426.

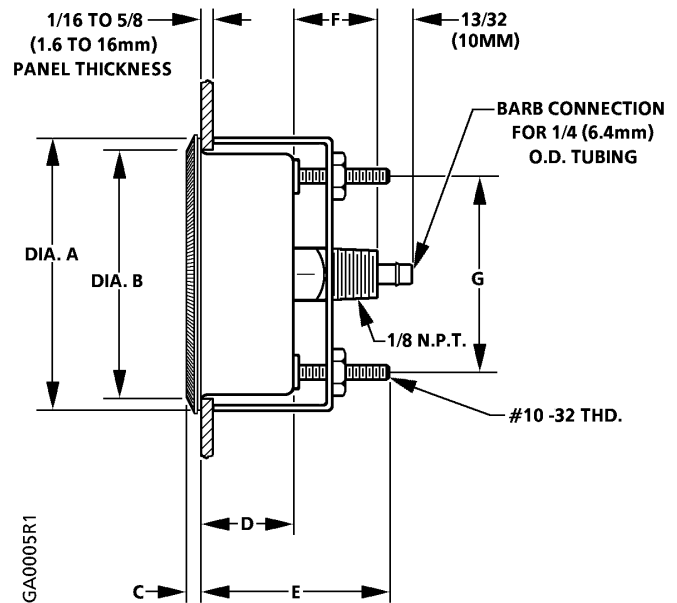
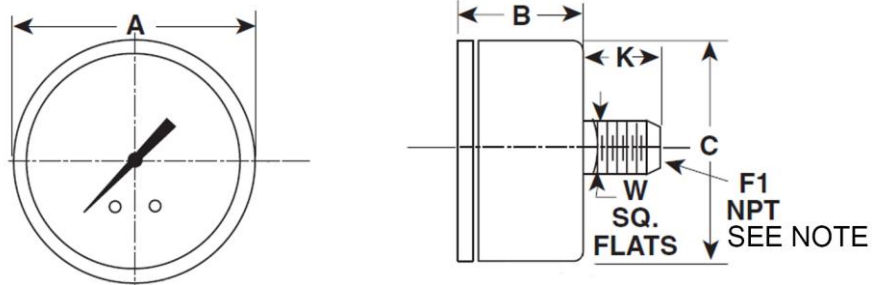

Figure 2. Dimensions for Table 3.

Table 3. Dimensions in Inches (mm). See Figure 2.

Product Number	Nominal Size	Dimensions							Graduations	
		A	B	C	D	E	F	G	Major	Minor
142-0274	1-1/2" (38)	1-13/16 (46)	1-19/32 (40)	—	3/4 (19)	1-1/8 (29)	21/32 (17)	1-1/8 (29)	5	1
142-0277	2-1/2" (64)	2-7/8 (73)	2-5/8 (67)	7/32 (5)	1 (25)	—	7/8 (29)	2 (51)	5	1
142-0311	2-1/2" (64)	2-23/32 (69)	2-11/16 (68)	—	1 (25)	—	7/8 (22)	—	5	1
142-0312	2-1/2" (64)	2-23/32 (69)	2-11/16 (68)	—	1 (25)	—	7/8 (22)	—	10	2
142-0313	2-1/2" (64)	2-23/32 (69)	2-11/16 (68)	—	1 (25)	—	7/8 (22)	—	20	5
142-0373	1-1/2" (38)	1-5/8 (41)	1-9/16 (40)	—	7/8 (22)	—	5/8 (16)	—	5 (20)	1 (5)
142-0426	See Figure 1.									

Table 4. Dimensions in Inches (mm) for Gauge 142-0473.



Dial Size Inches (mm)	A	B	C	F1 NPT	K	W	Weight Oz (kg)
	Back	Back				Back	
1.5 (38)	1.64 (42)	1.01 (26)	1.60 (41)	1/8	0.62 (16)	0.44 (11)	1.55 oz (0.044 kg)

NOTE: Teflon tape to be applied around the circumference of the brass socket pipe thread leaving only the first one-half to two threads free of tape.

Table 5. Dimensions in Inches (mm) for Gauge 142-0476.

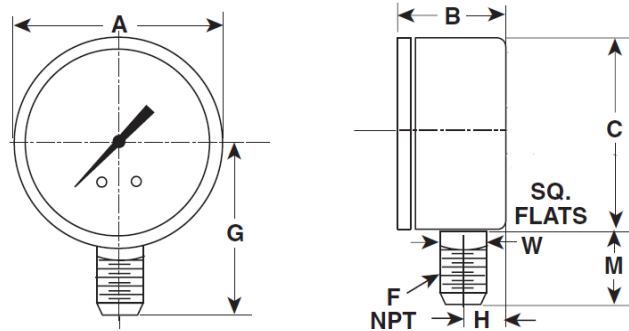

Dial Size Inches (mm)	A	B	C	F1 NPT	G	H	M	W	Weight Oz (kg)
	Lower	Lower						Lower	
1.5 (38)	1.66 (42)	1.07 (27)	1.60 (41)	1/8	1.41 (36)	0.38 (10)	0.62 (16)	0.56 (14)	1.62 oz (0.046 kg)

Information in this publication is based on current specifications. The company reserves the right to make changes in specifications and models as design improvements are introduced. POWERS is a registered trademark of Siemens Industry, Inc. Other product or company names mentioned herein may be the trademarks of their respective owners. © 2019 Siemens Industry, Inc.